



Product Features:

- 10BASE-T Ethernet RJ45
- IEEE802.3i Compliant
- 100% Compliance Testing
- 1500Vrms Hi-Pot
- Proprietary Robust Contact Design
- 30µ" Gold Plating on Contacts
- Integrated Butterworth Filter

Part Number (0 to 70°C)	Circuit	LED's (L/R)	Turns Ratio (± 3%)		Return Loss 5-10MHz	Attenuation (@30MHz)		Cutoff Frequency
			TX	RX		TX	RX	
HFJ11-S101ERL	A	None	1CT:1	1CT:1	-15dB	-30dB	-18dB	17MHz
HFJ11-S101E-L11RL	A	G/G	1CT:1	1CT:1	-15dB	-30dB	-18dB	17MHz
HFJ11-S101E-L12RL	A	G/Y	1CT:1	1CT:1	-15dB	-30dB	-18dB	17MHz
HFJ11-S101E-L17RL	A	G/G(O)	1CT:1	1CT:1	-15dB	-30dB	-18dB	17MHz
HFJ11-S101E-L21RL	A	Y/G	1CT:1	1CT:1	-15dB	-30dB	-18dB	17MHz
HFJ11-S101E-L51RL	A	G(Y)/G	1CT:1	1CT:1	-15dB	-30dB	-18dB	17MHz
HFJ11-S101E-L72RL	A	G(O)/Y	1CT:1	1CT:1	-15dB	-30dB	-18dB	17MHz
HFJ11-S114ERL	B	None	1CT:1.41	1CT:1	-15dB	-30dB	-18dB	17MHz
HFJ11-S114E-L11RL	B	G/G	1CT:1.41	1CT:1	-15dB	-30dB	-18dB	17MHz
HFJ11-S114E-L12RL	B	G/Y	1CT:1.41	1CT:1	-15dB	-30dB	-18dB	17MHz
HFJ11-S114E-L17RL	B	G/G(O)	1CT:1.41	1CT:1	-15dB	-30dB	-18dB	17MHz
HFJ11-S114E-L21RL	B	Y/G	1CT:1.41	1CT:1	-15dB	-30dB	-18dB	17MHz
HFJ11-S114E-L51RL	B	G(Y)/G	1CT:1.41	1CT:1	-15dB	-30dB	-18dB	17MHz
HFJ11-S114E-L72RL	B	G(O)/Y	1CT:1.41	1CT:1	-15dB	-30dB	-18dB	17MHz

Notes:

1. LED Key : G = Green, Y = Yellow, O = Orange, () = Bi-Color
2. Other LED colors, bi-colors, polarities, and current limiting versions available
3. Unshielded and without ground shield tabs available
4. Part specific datasheets available
5. Extended temperature available
6. Tab-up versions available
7. 1x2 and 1x4 ganged Fastjacks available
8. Additional turns ratios available

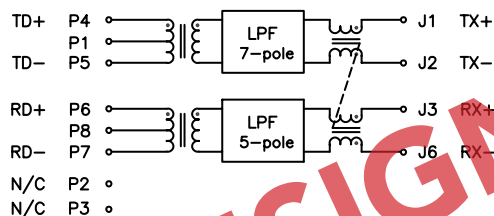
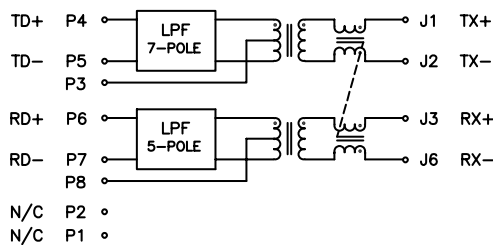

Mechanical

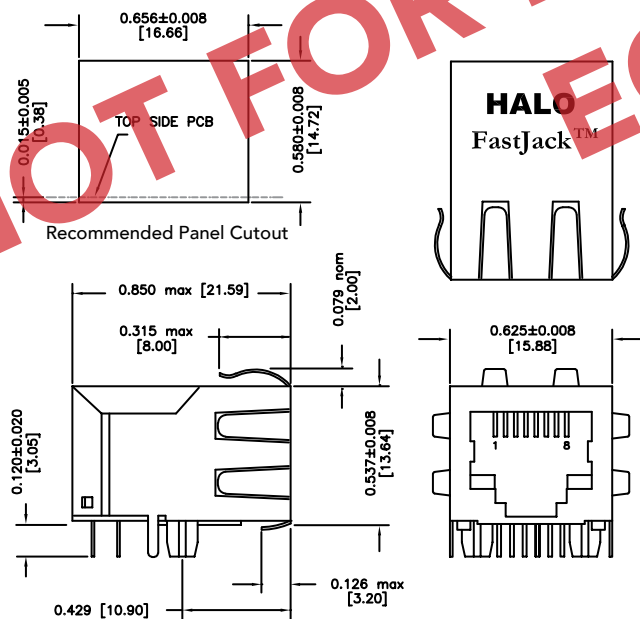

Dimensions are in inches [mm]

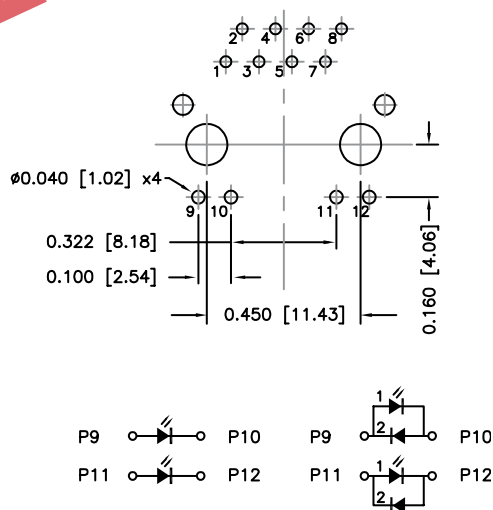

Recommended PCB Layout (Component Side)

* Parts numbers without LED's omit pins 9 through 12



2880 Lakeside Drive #116
 Santa Clara, CA 95054
 (650) 903-3800
www.haloelectronics.com

HALO® Electronics is a leading supplier of high quality communication magnetics including signal transformers, filters, CMR chokes, PoE power transformers, DC/DC converters, and integrated Ethernet connectors. HALO's leading edge technology solutions are manufactured in ISO9001 and ISO14001 factories offering high quality products at a competitive price.