

FastJack™ - 10Gigabit RJ45

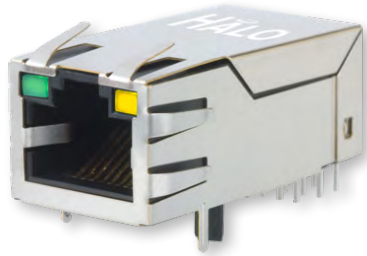

1x1 Tab-Up 10G Integrated RJ45



Product Features:

- 10G Ethernet RJ45
- IEEE802.3an Compliant
- Compatible with Current and Voltage Drive PHY's
- 100% Compliance Testing
- 1500Vrms Hi-Pot
- Hard Gold on Contacts
- Proprietary Robust Contact Design
- UL60950 and UL62368 Recognized

Part Number		Data Rate	LED's (L/R)	PoE	OCL (min)	DCMR	
Standard Temp (0 to 70°C)	Extended Temp (-40 to +85°C)					1-250MHz	250-500MHz
HFJT1-10G06C3RL	HFJT1-E10G06C3RL	10G	None	No	120μH	-35dB	-25dB
HFJT1-10G06C3-L11RL	HFJT1-E10G06C3-L11RL	10G	G/G	No	120μH	-35dB	-25dB
HFJT1-10G06C3-L12RL	HFJT1-E10G06C3-L12RL	10G	G/Y	No	120μH	-35dB	-25dB
HFJT1-10G06C3-L21RL	HFJT1-E10G06C3-L21RL	10G	Y/G	No	120μH	-35dB	-25dB

Notes:

1. LED Key : G = Green, Y = Yellow
2. Other LED colors, bi-colors, polarities, and current limiting versions available
3. Part specific datasheets available upon request

Circuit Diagram

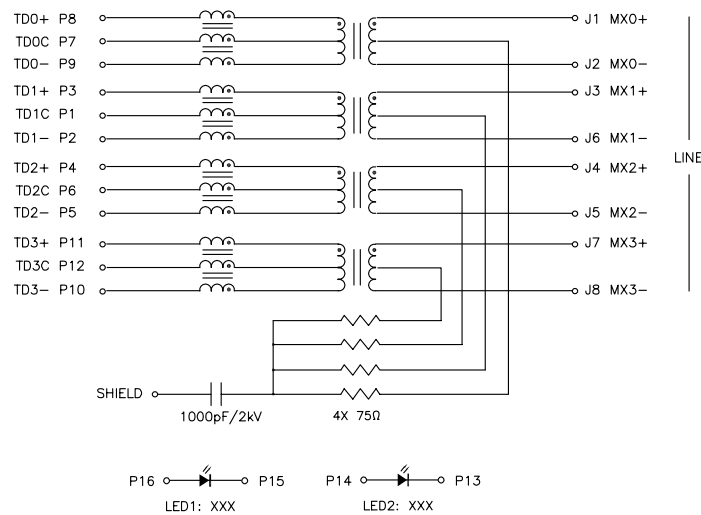

For additional information contact your [local representative](#), or HALO's support staff at (650) 903-3800 or info@haloelectronics.com

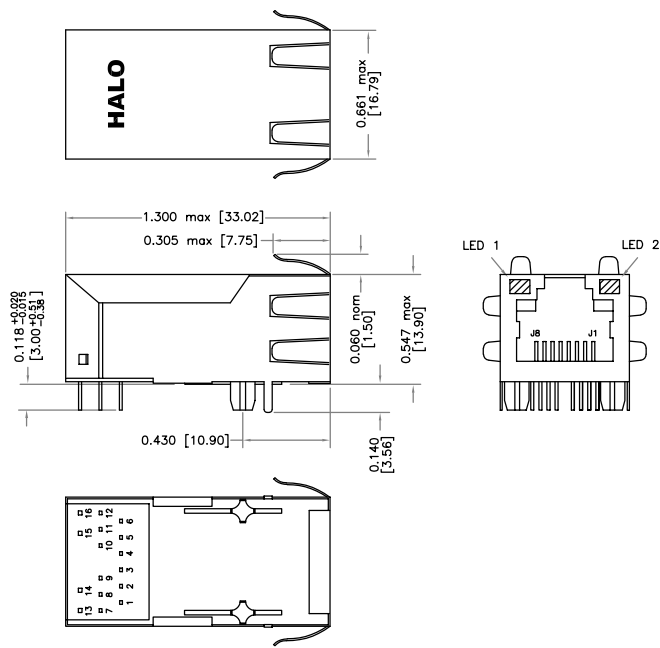

Dimensions are in inch [mm]

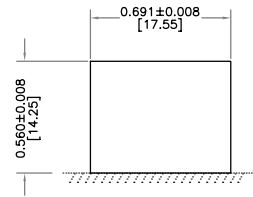

RECOMMENDED PANEL CUT

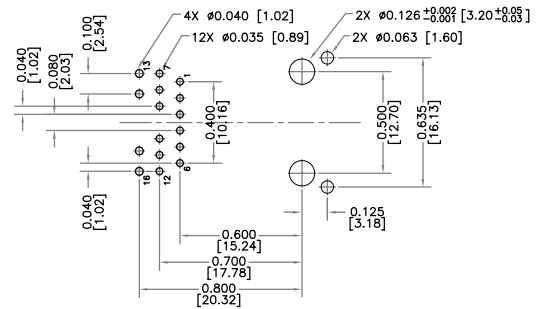

Recommended PCB Layout (Component Side)

* Part numbers without LED's omit pins 13 - 16



Santa Clara, CA
(650) 903-3800

www.haloelectronics.com

HALO® Electronics is a leading supplier of high quality communication magnetics including signal transformers, filters, CMR chokes, PoE power transformers, DC/DC converters, and integrated Ethernet connectors. HALO's leading edge technology solutions are manufactured in ISO9001 and ISO14001 factories offering high quality products at a competitive price.