

FastJack™ - 10Gig PoE RJ45

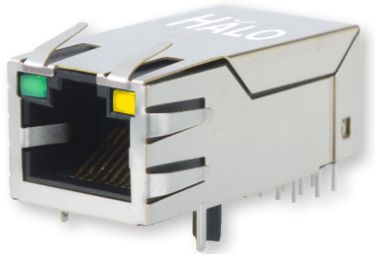

1x1 Tab-Up 10G Integrated RJ45 w/ PoE



Product Features:

- 10G Ethernet RJ45
- IEEE802.3an/af/at/bt Compliant
- Compatible with Current and Voltage Drive PHY's
- 100% Compliance Testing
- 1500Vrms Hi-Pot
- Hard Gold on Contacts
- Proprietary Robust Contact Design
- UL60950 and UL62368 Recognized

Part Number		Data Rate	LED's (L/R)	PoE+	4PPoE	Current Per Pair
Standard Temp (0 to 70°C)	Extended Temp (-40 to +85°C)					
HFJT1-10GHPRL	HFJT1-10GHPERL	10G	None	✓	✓	600mA
HFJT1-10GHP-L11RL	HFJT1-10GHPE-L11RL	10G	G/G	✓	✓	600mA
HFJT1-10GHP-L12RL	HFJT1-10GHPE-L12RL	10G	G/Y	✓	✓	600mA
HFJT1-10GHP-L21RL	HFJT1-10GHPE-L21RL	10G	Y/G	✓	✓	600mA
HFJT1-10GH4PRL	HFJT1-10GH4PERL	10G	None	✓	✓	1A
HFJT1-10GH4P-L11RL	HFJT1-10GH4PE-L11RL	10G	G/G	✓	✓	1A
HFJT1-10GH4P-L12RL	HFJT1-10GH4PE-L12RL	10G	G/Y	✓	✓	1A
HFJT1-10GH4P-L21RL	HFJT1-10GH4PE-L21RL	10G	Y/G	✓	✓	1A

Notes:

1. LED Key : G = Green, Y = Yellow
2. Other LED colors, bi-colors, polarities, and current limiting versions available
3. Part specific datasheets available upon request
4. Footprint interchangeable with other [Gigabit PoE](#) and [2.5/5G PoE Tab-Up FastJacks](#)

HALO 10G PoE Integrated RJ45 FastJack

Circuit Diagram

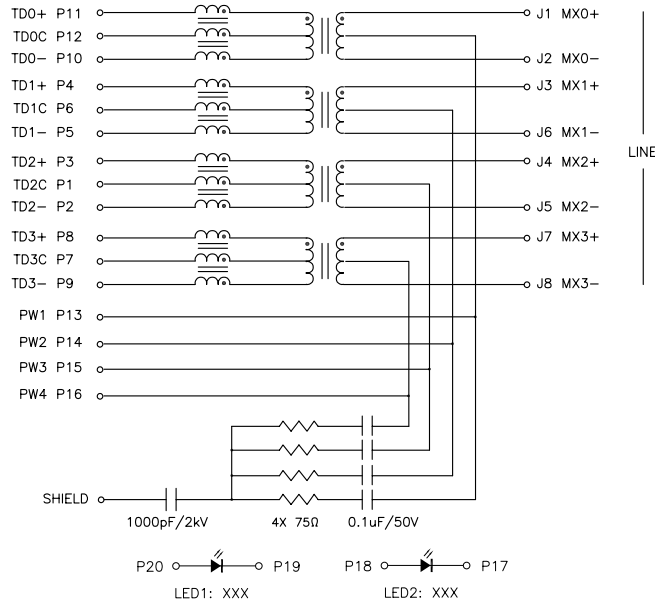

Mechanical

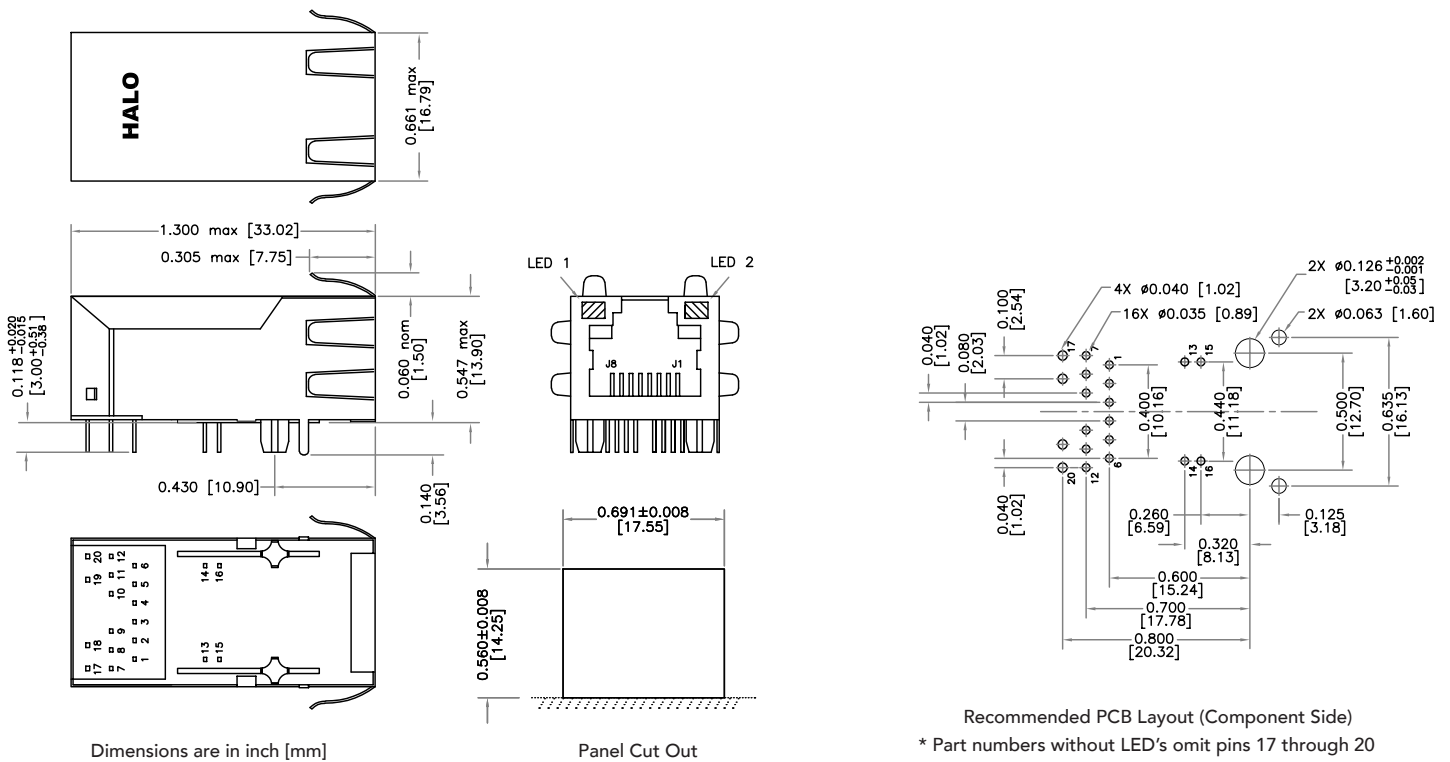

Santa Clara, CA
(650) 903-3800

www.haloelectronics.com

HALO® Electronics is a leading supplier of high quality communication magnetics including signal transformers, filters, CMR chokes, PoE power transformers, DC/DC converters, and integrated Ethernet connectors. HALO's leading edge technology solutions are manufactured in ISO9001 and ISO14001 factories offering high quality products at a competitive price.